

## Precision Dial Gauges

The well thought-out design, accurate components and robust construction of our Precision Dial Gauge series offer reliability, durability and long working life. The standard features that enhance the quality across our entire product range are:

- Calibrations of all Dial Gauges are traceable to national and international standards.
- The final quality control for the whole series includes visual inspection and full mechanical functions' tests.
- Supplied with Declaration of Conformity and Confirmation of Traceability.
- Materials and components selected specifically to ensure a long working life.

### Technical Benefits of our metric Precision Dial Gauges

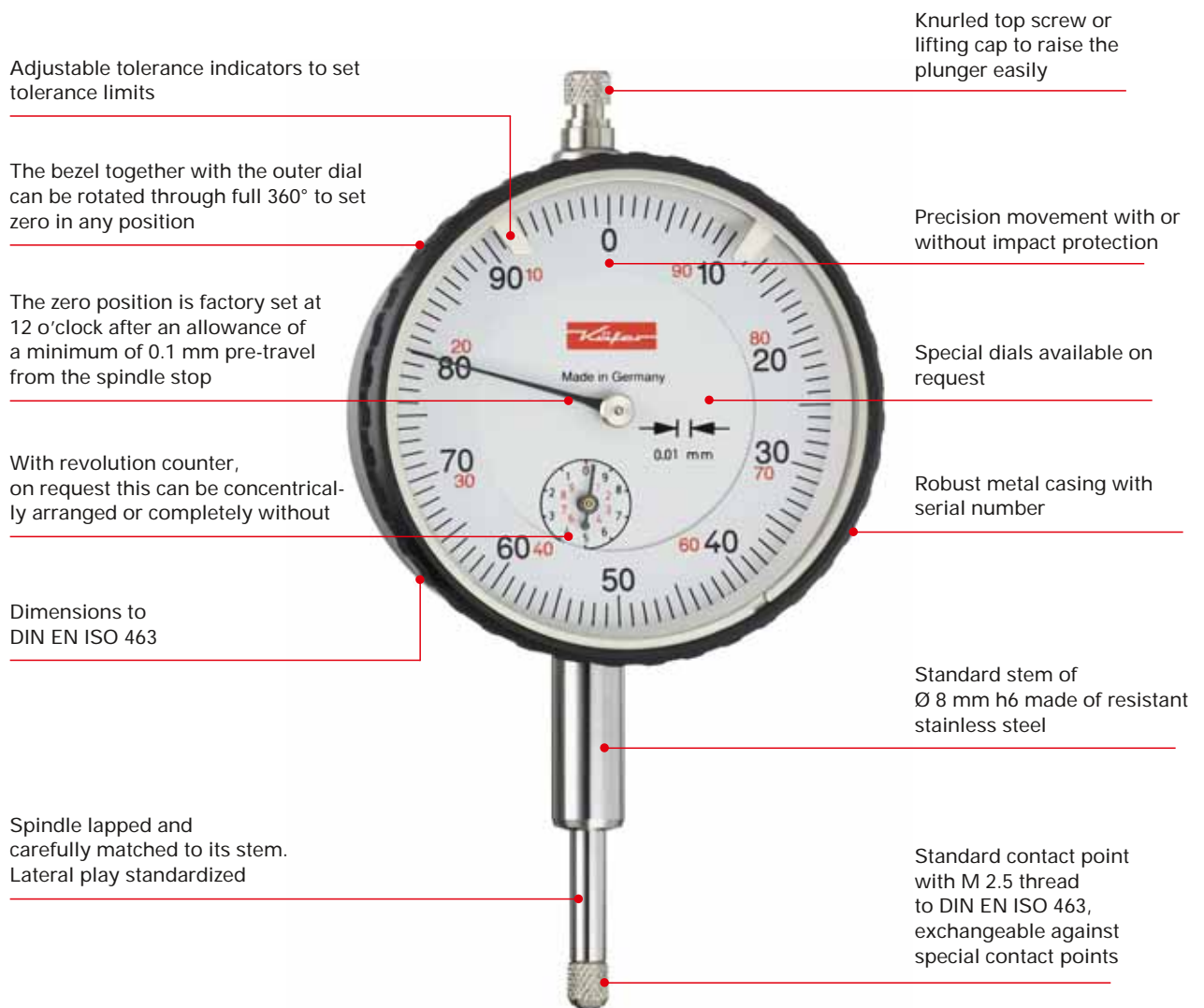

# Precision Dial Gauges

## Specifications of the Technical Data of Metric Dial Gauges

| Page | Model                       | Reading      | Range per revolution | Range  | Bezel-Ø | Special Feature                         |
|------|-----------------------------|--------------|----------------------|--------|---------|---|
| 42   | KM 5 a                      | 0.1 mm       | 5 mm                 | 5 mm   | 40 mm   |   |
| 42   | KM 10 a                     | 0.1 mm       | 10 mm                | 10 mm  | 40 mm   |   |
| -    | KM 5 a R                    | 0.1 mm       | 5 mm                 | 5 mm   | 40 mm   | Back Plunger                            |
| 43   | M 10 a                      | 0.1 mm       | 10 mm                | 10 mm  | 58 mm   |   |
| 43   | M 10 b                      | 0.1 mm       | 10 mm                | 20 mm  | 58 mm   |   |
| 44   | M 10 c                      | 0.1 mm       | 10 mm                | 30 mm  | 58 mm   |   |
| 44   | M 10 d                      | 0.1 mm       | 10 mm                | 50 mm  | 58 mm   |   |
| -    | M 10/5 R                    | 0.1 mm       | 5 mm                 | 5 mm   | 58 mm   | Back Plunger                            |
| -    | SI-9/0.1                    | 0.1 mm       | -                    | 8 mm   | 58 mm   | Error Free                              |
| -    | GM 10/80                    | 0.1 mm       | 10 mm                | 20 mm  | 80 mm   |   |
| -    | GM 10/100                   | 0.1 mm       | 10 mm                | 10 mm  | 100 mm  |   |
| 24   | MU 28                       | 0.01 mm      | 0.5 mm               | 3.5 mm | 28 mm   |   |
| 24   | KM 6 T                      | 0.01 mm      | 0.5 mm               | 3 mm   | 32 mm   |   |
| 25   | KM 4 T                      | 0.01 mm      | 0.5 mm               | 3 mm   | 40 mm   |   |
| -    | KM 4 T - 100                | 0.01 mm      | 1.0 mm               | 3 mm   | 40 mm   |   |
| 27   | KM 4 TOP                    | 0.01 mm      | 0.5 mm               | 3 mm   | 40 mm   |   |
| 30   | KM 4 S                      | 0.01 mm      | 0.5 mm               | 3 mm   | 40 mm   | Shockproof                              |
| -    | KM 4 S - 100                | 0.01 mm      | 1.0 mm               | 3 mm   | 40 mm   | Shockproof                              |
| -    | KM 4 TOP ,S'                | 0.01 mm      | 0.5 mm               | 3 mm   | 40 mm   | Shockproof                              |
| 26   | KM 4/5 T                    | 0.01 mm      | 0.5 mm               | 5 mm   | 40 mm   |   |
| 29   | KM 4/5 T - 100              | 0.01 mm      | 1.0 mm               | 5 mm   | 40 mm   |   |
| 28   | KMU 4/5 TK - 100            | 0.01 mm      | 1.0 mm               | 5 mm   | 40 mm   | Concentric Hands                        |
| -    | KM 4/5 TOP                  | 0.01 mm      | 0.5 mm               | 5 mm   | 40 mm   |   |
| 31   | KM 4/5 S                    | 0.01 mm      | 0.5 mm               | 5 mm   | 40 mm   | Shockproof                              |
| -    | KM 4/5 S - 100              | 0.01 mm      | 1.0 mm               | 5 mm   | 40 mm   | Shockproof                              |
| 27   | KM 4/5 TOP ,S'              | 0.01 mm      | 0.5 mm               | 5 mm   | 40 mm   | Shockproof                              |
| 29   | KM 4/10 TK - 100            | 0.01 mm      | 1.0 mm               | 10 mm  | 40 mm   | Concentric Hands                        |
| 45   | KM 4 R                      | 0.01 mm      | 0.5 mm               | 3 mm   | 40 mm   | Back Plunger                            |
| 45   | KM 4/5 R                    | 0.01 mm      | 0.5 mm               | 5 mm   | 40 mm   | Back Plunger                            |
| 48   | SI-45                       | 0.01 mm      | -                    | 0.4 mm | 40 mm   | Error Free                              |
| -    | SI-45 W                     | 0.01 mm      | -                    | 0.4 mm | 44.5 mm | Error Free, Waterproof                  |
| 48   | SI-45/0.8                   | 0.01 mm      | -                    | 0.8 mm | 40 mm   | Error Free                              |
| 54   | KM 4 SW                     | 0.01 mm      | 0.5 mm               | 3 mm   | 44.5 mm | Waterproof                              |
| 54   | KM 4/5 SW                   | 0.01 mm      | 0.5 mm               | 5 mm   | 44.5 mm | Waterproof                              |
| -    | KM 4 S wa                   | 0.01 mm      | 0.5 mm               | 3 mm   | 41 mm   | Water Protected                         |
| 104  | KM 4 T Magnet               | 0.01 mm      | 0.5 mm               | 3 mm   | 40 mm   | Magnetic Back                           |
| 7    | M 2 T                       | 0.01 mm      | 1 mm                 | 10 mm  | 58 mm   |   |
| 8    | M 2 TK                      | 0.01 mm      | 1 mm                 | 10 mm  | 58 mm   | Concentric Hands                        |
| 9    | M 2 T with special fittings | 0.01/0.02 mm | 1/2 mm               | 10 mm  | 58 mm   | Special Transmission Ratio, Two Stems   |
| 10   | M 2 TOP                     | 0.01 mm      | 1 mm                 | 10 mm  | 58 mm   |   |
| 11   | M 2 X                       | 0.01 mm      | 1 mm                 | 10 mm  | 58 mm   |   |
| 12   | MU 52 T                     | 0.01 mm      | 1 mm                 | 10 mm  | 58 mm   |   |
| 14   | M 2 S                       | 0.01 mm      | 1 mm                 | 10 mm  | 58 mm   | Fine adjustment of the hand, Shockproof |
| 13   | M 2 SN                      | 0.01 mm      | 1 mm                 | 10 mm  | 58 mm   | Shockproof                              |
| 15   | M 2 TOP ,S'                 | 0.01 mm      | 1 mm                 | 10 mm  | 58 mm   | Shockproof                              |
| 15   | M 2 XS                      | 0.01 mm      | 1 mm                 | 10 mm  | 58 mm   | Shockproof                              |
| 12   | MU 52 ST                    | 0.01 mm      | 1 mm                 | 10 mm  | 58 mm   | Shockproof                              |
| 16   | M 3 T                       | 0.01 mm      | 0.5 mm               | 5 mm   | 58 mm   |   |
| 16   | M 3 S                       | 0.01 mm      | 0.5 mm               | 5 mm   | 58 mm   | Shockproof                              |
| 17   | M 2/20 T                    | 0.01 mm      | 1 mm                 | 20 mm  | 58 mm   |   |
| 17   | M 2/20 S                    | 0.01 mm      | 1 mm                 | 20 mm  | 58 mm   | Shockproof                              |
| 17   | M 2/25 T                    | 0.01 mm      | 1 mm                 | 25 mm  | 58 mm   | Compact Size                            |
| 17   | M 2/25 S                    | 0.01 mm      | 1 mm                 | 25 mm  | 58 mm   | Compact Size, Shockproof                |
| 18   | M 2/30 T                    | 0.01 mm      | 1 mm                 | 30 mm  | 58 mm   |   |
| 19   | M 2/30 S                    | 0.01 mm      | 1 mm                 | 30 mm  | 58 mm   | Shockproof                              |
| 20   | MU 2/30 T                   | 0.01 mm      | 1 mm                 | 30 mm  | 58 mm   |   |
| 20   | MU 2/30 S                   | 0.01 mm      | 1 mm                 | 30 mm  | 58 mm   | Shockproof                              |
| 21   | M 2/50 T                    | 0.01 mm      | 1 mm                 | 50 mm  | 58 mm   |   |
| 21   | M 2/50 S                    | 0.01 mm      | 1 mm                 | 50 mm  | 58 mm   | Shockproof                              |
| 22   | M 2/80 T                    | 0.01 mm      | 1 mm                 | 80 mm  | 58 mm   |   |
| 22   | M 2/80 S                    | 0.01 mm      | 1 mm                 | 80 mm  | 58 mm   | Shockproof                              |
| -    | M 2/100 T                   | 0.01 mm      | 1 mm                 | 100 mm | 58 mm   | Stem dia. 10 mm                         |

>>>

# Precision Dial Gauges

## Specifications of the Technical Data of Metric Dial Gauges

| Page | Model             | Reading  | Range per revolution | Range   | Bezel-Ø | Special Feature            |
|------|-------------------|----------|----------------------|---------|---------|----------------------------|
| 46   | M 2 R             | 0.01 mm  | 1 mm                 | 3 mm    | 58 mm   | Back Plunger               |
| 46   | M 2/5 R           | 0.01 mm  | 1 mm                 | 5 mm    | 58 mm   | Back Plunger               |
| 56   | M 2 RW            | 0.01 mm  | 1 mm                 | 3 mm    | 58 mm   | Back Plunger, Waterproof   |
| 49   | SI-90             | 0.01 mm  | –                    | 0.8 mm  | 58 mm   | Error Free                 |
| –    | SI-90 X           | 0.01 mm  | –                    | 0.8 mm  | 58 mm   | Error Free                 |
| 51   | MU 52 ST – SI     | 0.01 mm  | –                    | 0.8 mm  | 58 mm   | Error Free                 |
| –    | SI-90 R           | 0.01 mm  | –                    | 0.8 mm  | 58 mm   | Error Free, Back Plunger   |
| 57   | SI-90 W           | 0.01 mm  | –                    | 0.8 mm  | 61.5 mm | Error Free, Waterproof     |
| 50   | SI-100            | 0.01 mm  | –                    | 1 mm    | 58 mm   | Error Free                 |
| 49   | SI-18             | 0.01 mm  | –                    | 1.6 mm  | 58 mm   | Error Free                 |
| 55   | M 2 SW            | 0.01 mm  | 1 mm                 | 10 mm   | 61.5 mm | Waterproof                 |
| 56   | M 2/30 SW         | 0.01 mm  | 1 mm                 | 30 mm   | 61.5 mm | Waterproof                 |
| 60   | M 2 S wa          | 0.01 mm  | 1 mm                 | 10 mm   | 58 mm   | Water Protected            |
| 104  | M 2 T Magnet      | 0.01 mm  | 1 mm                 | 10 mm   | 58 mm   | Magnetic Back              |
| –    | M 2 T Antimagnet  | 0.01 mm  | 1 mm                 | 10 mm   | 58 mm   | Antimagnetic               |
| 32   | GM 80 T           | 0.01 mm  | 1 mm                 | 10 mm   | 80 mm   |                            |
| 32   | GM 80 S           | 0.01 mm  | 1 mm                 | 10 mm   | 80 mm   | Shockproof                 |
| –    | GM 80/30 T        | 0.01 mm  | 1 mm                 | 30 mm   | 80 mm   |                            |
| –    | GM 80/50 T        | 0.01 mm  | 1 mm                 | 50 mm   | 80 mm   |                            |
| 23   | GM 80/100 T       | 0.01 mm  | 1 mm                 | 100 mm  | 80 mm   | Stem dia. 10 mm            |
| 58   | GM 80 SW          | 0.01 mm  | 1 mm                 | 10 mm   | 80 mm   | Waterproof                 |
| 32   | GM 100 T          | 0.01 mm  | 1 mm                 | 10 mm   | 100 mm  |                            |
| 32   | GM 100 S          | 0.01 mm  | 1 mm                 | 10 mm   | 100 mm  | Shockproof                 |
| –    | GM 100/30 T       | 0.01 mm  | 1 mm                 | 30 mm   | 100 mm  |                            |
| –    | GM 100/50 T       | 0.01 mm  | 1 mm                 | 50 mm   | 100 mm  |                            |
| 16   | M 3 a T           | 0.005 mm | 0.5 mm               | 5 mm    | 58 mm   |                            |
| 16   | M 3 a S           | 0.005 mm | 0.5 mm               | 5 mm    | 58 mm   | Shockproof                 |
| –    | M 3 a SI          | 0.005 mm | –                    | 0.4 mm  | 58 mm   | Error Free                 |
| –    | KM 500 T          | 0.002 mm | 0.2 mm               | 1 mm    | 40 mm   |                            |
| 34   | KM 500 S          | 0.002 mm | 0.2 mm               | 1 mm    | 40 mm   | Shockproof                 |
| –    | KM 500/3 S        | 0.002 mm | 0.2 mm               | 3 mm    | 40 mm   | Shockproof                 |
| –    | KM 500 R          | 0.002 mm | 0.2 mm               | 1 mm    | 40 mm   | Back Plunger               |
| –    | KM 500 SI         | 0.002 mm | –                    | 0.16 mm | 40 mm   | Error Free                 |
| –    | KM 500 SW         | 0.002 mm | 0.2 mm               | 1 mm    | 44.5 mm | Waterproof                 |
| 35   | FM 500 T          | 0.002 mm | 0.2 mm               | 1 mm    | 58 mm   |                            |
| –    | FM 500 R          | 0.002 mm | 0.2 mm               | 1 mm    | 58 mm   | Back Plunger               |
| –    | FM 500 SI         | 0.002 mm | –                    | 0.16 mm | 58 mm   | Error Free                 |
| –    | KM 1000 T         | 0.001 mm | 0.2 mm               | 1 mm    | 40 mm   |                            |
| –    | KM 1000 S         | 0.001 mm | 0.2 mm               | 1 mm    | 40 mm   | Shockproof                 |
| 39   | Feinika KM 1101   | 0.001 mm | 0.1 mm               | 1 mm    | 40 mm   | Shockproof, extra accurate |
| –    | KM 1000/3 T       | 0.001 mm | 0.2 mm               | 3 mm    | 40 mm   |                            |
| –    | KM 1000/3 S       | 0.001 mm | 0.2 mm               | 3 mm    | 40 mm   | Shockproof                 |
| –    | KM 1000/5 T       | 0.001 mm | 0.2 mm               | 5 mm    | 40 mm   |                            |
| –    | KM 1000/5 S       | 0.001 mm | 0.2 mm               | 5 mm    | 40 mm   | Shockproof                 |
| –    | KM 1000 R         | 0.001 mm | 0.2 mm               | 1 mm    | 40 mm   | Back Plunger               |
| 52   | Feinika SI-914    | 0.001 mm | –                    | 0.08 mm | 40 mm   | Error Free                 |
| –    | Feinika SI-910    | 0.001 mm | –                    | 0.10 mm | 40 mm   | Error Free                 |
| –    | KM 1000 SI        | 0.001 mm | –                    | 0.16 mm | 40 mm   | Error Free                 |
| –    | KM 1000 S wa      | 0.001 mm | 0.2 mm               | 1 mm    | 40 mm   | Water Protected            |
| –    | Feinika KM 1101 W | 0.001 mm | 0.1 mm               | 1 mm    | 44.5 mm | Waterproof                 |
| 35   | FM 1000 T         | 0.001 mm | 0.2 mm               | 1 mm    | 58 mm   |                            |
| –    | FM 1000 S         | 0.001 mm | 0.2 mm               | 1 mm    | 58 mm   | Shockproof                 |
| 40   | Feinika FM 1101   | 0.001 mm | 0.1 mm               | 1 mm    | 58 mm   | Shockproof, extra accurate |
| 37   | FM 1000/5 T       | 0.001 mm | 0.2 mm               | 5 mm    | 58 mm   |                            |
| 36   | FM 1000/5 S       | 0.001 mm | 0.2 mm               | 5 mm    | 58 mm   | Shockproof                 |
| –    | FM 1000 R         | 0.001 mm | 0.2 mm               | 1 mm    | 58 mm   | Back Plunger               |
| 52   | Feinika SI-915    | 0.001 mm | –                    | 0.08 mm | 58 mm   | Error Free                 |
| –    | Feinika SI-916    | 0.001 mm | –                    | 0.10 mm | 58 mm   | Error Free                 |
| –    | Feinika SI-918    | 0.001 mm | –                    | 0.16 mm | 58 mm   | Error Free                 |
| –    | SI-180            | 0.001 mm | –                    | 0.16 mm | 58 mm   | Error Free                 |
| –    | FM 1000 S wa      | 0.001 mm | 0.2 mm               | 1 mm    | 58 mm   | Water Protected            |
| 59   | FM 1000 SW        | 0.001 mm | 0.2 mm               | 1 mm    | 61.5 mm | Waterproof                 |
| –    | Feinika FM 1101 W | 0.001 mm | 0.1 mm               | 1 mm    | 61.5 mm | Waterproof                 |
| –    | FM 1000/5 S wa    | 0.001 mm | 0.2 mm               | 5 mm    | 58 mm   | Water Protected            |
| 59   | FM 1000/5 SW      | 0.001 mm | 0.2 mm               | 5 mm    | 61.5 mm | Waterproof                 |
| –    | FM 1000/80 T      | 0.001 mm | 0.2 mm               | 1 mm    | 80 mm   |                            |
| –    | FM 1000/80 S      | 0.001 mm | 0.2 mm               | 1 mm    | 80 mm   | Shockproof                 |
| –    | FM 1000/80-5 T    | 0.001 mm | 0.2 mm               | 5 mm    | 80 mm   |                            |
| –    | FM 1000/80-5 S    | 0.001 mm | 0.2 mm               | 5 mm    | 80 mm   | Shockproof                 |



# Dial Gauge M 2 T

A well thought-out design, the use of high-quality components and materials as well as the precision engineered mechanism guarantee the outstanding quality of the Precision Dial Gauge M 2 T.

All details of this Dial Gauge conform to DIN 878 in conjunction with DIN EN ISO 463. This applies not only to the outside dimensions but also to allowed tolerances, the measuring force and the measuring force reversal range.

Spindle and stem are made of resistant stainless steel. The spindle is lapped.

| Precision Dial Gauge M 2 T                                    |                         |
|---|-------------------------|
| Reading   | 0.01 mm                 |
| Range   | 10 mm                   |
| Range per revolution  | 1 mm                    |
| Bezel-Ø   | 58 mm                   |
| Stem-Ø  | 8 h 6                   |
| Dimensions and accuracy according to DIN EN ISO 463 / DIN 878 |                         |
| Initial measuring force                                       | 0.7 N ± 20%             |
| Dimensioned drawing   | page 7                  |
| Data sheet to DIN EN ISO 463                                  | www.kaefer-messuhren.de |

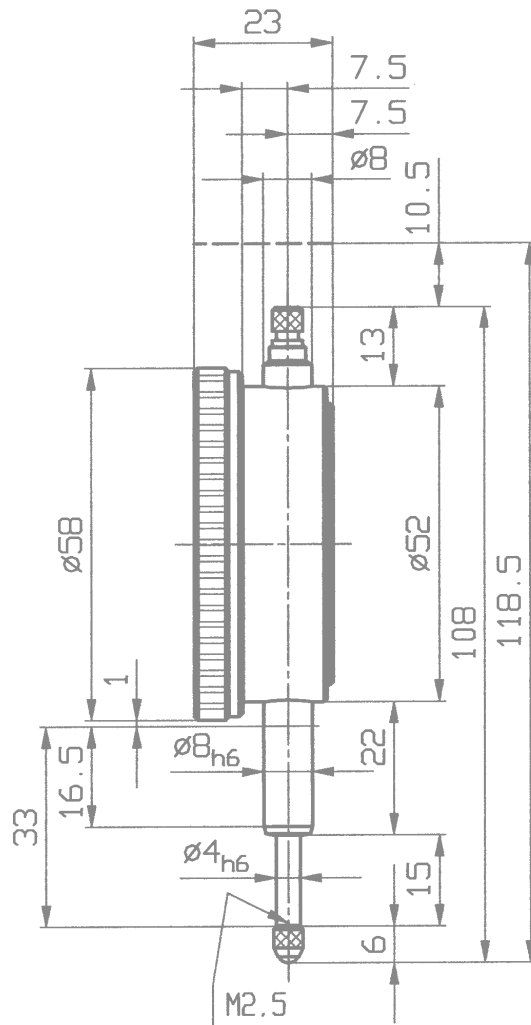

**Model M 1 T** is a Dial Gauge with the same technical data but with only one large hand and no revolution counter.

Special fittings:







## Dial Gauge M 2 T with special fittings

| Precision Dial Gauge M 2 T with range per revolution = 2 mm |                        |
|---|------------------------|
| Reading   | 0.02 mm                |
| Range   | 10 mm                  |
| Range per revolution  | 2 mm                   |
| Bezel-Ø   | 58 mm                  |
| Stem-Ø  | 8 h 6                  |
| Dimensions and accuracy according to                        | DIN EN ISO 463/DIN 878 |
| Initial measuring force                                     | 0.7 N ± 20%            |
| Dimensioned drawing   | page 7                 |

| Precision Dial Gauge M 2 T with two stems: top and bottom |                          |
|---|--------------------------|
| Reading   | 0.01 mm                  |
| Range   | 10 mm                    |
| Range per revolution                                      | 1 mm                     |
| Bezel-Ø   | 58 mm                    |
| Stem-Ø  | 8 h 6                    |
| Dimensions and accuracy according to                      | DIN EN ISO 463 / DIN 878 |
| Initial measuring force                                   | 0.7 N ± 20%              |
| Dimensioned drawing                                       | on request               |



Model shown: M 2 T with two stems

On request other Dial Gauges from our manufacturing programme are available with special transmission ratio or with two stems. Please request our offers.

Special fittings:





## Dial Gauge M 2 TOP

New technological production methods enable us to market it at an astonishingly low price.

All details of this Dial Gauge conform to DIN 878 in conjunction with DIN EN ISO 463. This applies not only to the dimensions but also to allowed tolerances.

Spindle and stem are made of resistant stainless steel. The spindle is lapped.

| Precision Dial Gauge M 2 TOP                                  |  |
|---|--|
| Reading   | 0.01 mm  |
| Range   | 10 mm  |
| Range per revolution  | 1 mm   |
| Bezel-Ø   | 58 mm  |
| Stem-Ø  | 8 h 6  |
| Dimensions and accuracy according to DIN EN ISO 463 / DIN 878 |  |
| Initial measuring force                                       | 0.7 N ± 20%  |
| Dimensioned drawing   | page 10  |
| Data sheet to DIN EN ISO 463                                  | <a href="http://www.kaefer-messuhren.de">www.kaefer-messuhren.de</a> |

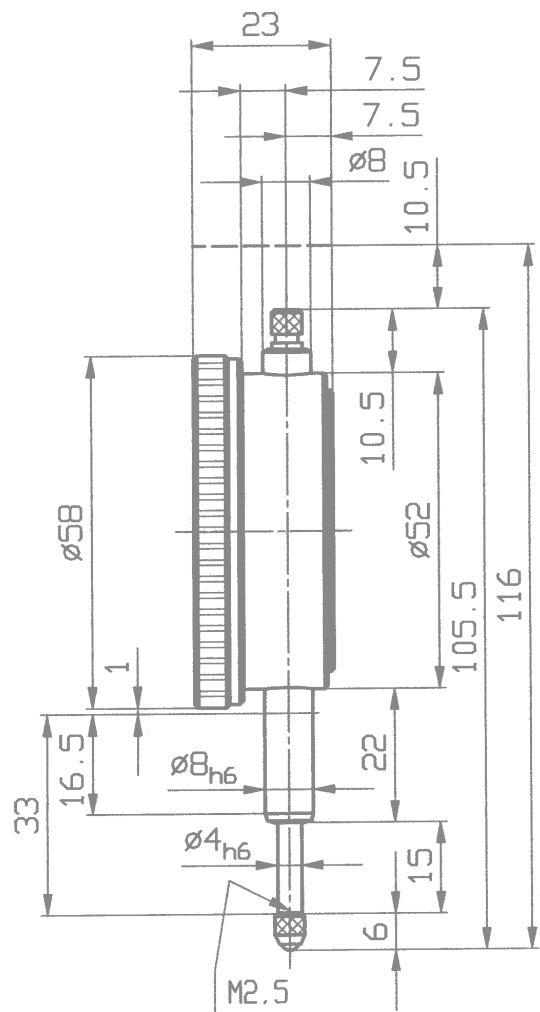

Special fittings:

10



## Additional Equipment for Mechanical Dial Gauges

### Locking screw

The knurled bezel on Dial Gauges can be turned with the outer dials. This allows zero point adjustment.

In order to avoid unintentional adjustment, Dial Gauges can be supplied with locking plate and knurled screw at extra charge for the purpose of locking the bezel.

Following Dial Gauges are available with the locking screw:

- range not greater than 80 mm
- no model of the X series
- bezel-Ø 40 or 58 mm

Retrofitting of this device to existing Dial Gauges is not possible.

### Slave Pointer

On Dial Gauges with slave pointer facility, the displayed measured value remains visible after the dial gauge pointer returns to its original setting, because the additional pointer dragged along with it stays at the position from where the main pointer returns.

It must be noted that the slave pointer facility is only effective within one pointer revolution.

Following Dial Gauges without concentric small hands are available with a slave pointer device:

- reading 0.1 or 0.01 mm
- not shockproof
- bezel Ø 40 or 58 mm

Retrofitting of this device to existing Dial Gauges is possible.

### Lifting Device

The lifting lever permits quick lifting of the spindle. The lever itself can be swivelled and permits its use in the most comfortable position.

Lifting devices are available in 2 sizes for Dial Gauges with ranges up to 10 mm and for Dial Gauge models with range of 30 mm.

Following Dial Gauges are available with lifting device:

- range up to 10 mm
- bezel Ø 40 or 58 mm
- range up to 30 mm
- bezel Ø 58 mm

Retrofitting of this device is possible on condition that the Dial Gauge is not fitted with a protection sleeve and that it is not a model of the X-series.





## Additional Equipment for Mechanical Dial Gauges



### Magnetic Back

Magnetic backs allow Dial Gauges to be used without a holder and without a stand. The magnet, made of sinter metal does in no way affect the mechanism of the Dial Gauge.

Magnetic backs are available in 2 sizes for the following Dial Gauges:

- Dial Gauges with 40 mm (1 9/16") Ø
- Dial Gauges with 58 mm (2 1/4") Ø or larger

Retrofitting of magnetic backs is possible.

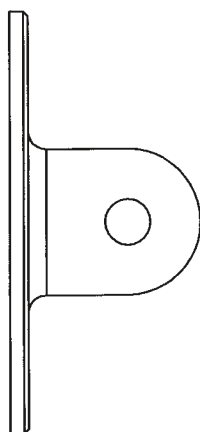

### Lug Back

Lug backs are available in 3 sizes for:

- Dial Gauges with 32 mm (1 13/50") Ø
- Dial Gauges with 40 mm (1 9/16") Ø
- Dial Gauges with 58 mm (2 1/4") Ø or larger.

The standard bore diameter in the fixing lug is 5 mm. Delivery of Dial Gauges conforming to American standards with 1/4" bore diameter. On request a bore diameter of 6 mm is also possible.

Retrofitting of lug backs is possible.

Offset lug backs are available on request.

### Special Backs

All standard model Dial Gauges will be delivered with flat backs. Delivery of special back versions on request. Retrofitting is possible.

#### **Post type backs with post Ø 12.7 mm (.500")**

- Back with drawing number 020603/2 is for models AGD1 (40 mm Ø)
- Back with drawing number 020603/1 is for models AGD 2 (58 mm Ø)

#### **Screw type backs with female thread 1/4-20UNC**

- Back with drawing number 020603/4 is for models AGD1 (40 mm Ø)
- Back with drawing number 020603/3 is for models AGD 2 (58 mm Ø)

#### **Back with adjustable bracket**

- Back with drawing number 020308/3 is for models AGD 2 (58 mm Ø)

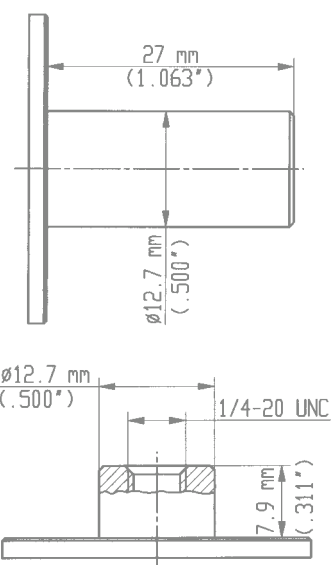

## Special Dials for mechanical Dial Gauges

### Dials with coloured tolerance segments

The colours red, green and yellow are available. Please indicate in your order text what segments of the dial should be marked red, green or yellow.

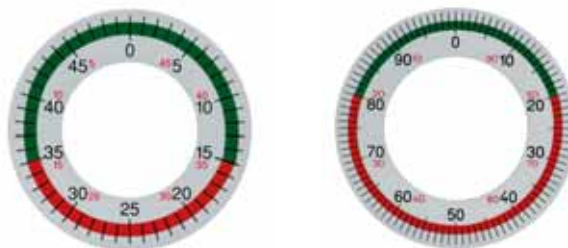

### Dials for anti-clockwise reading

Unless otherwise stated on the order both the inner and outer dials are supplied for anti-clockwise reading.

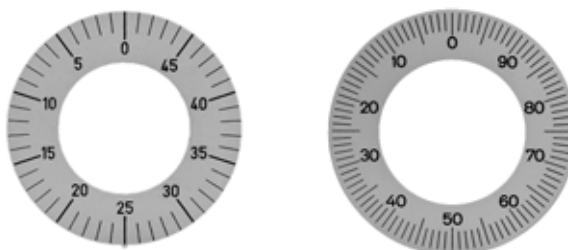

### Balanced Dials

Unless otherwise stated on the order only the outer dial is supplied with balanced numbers. The inner dial is supplied with numbers for clockwise reading.

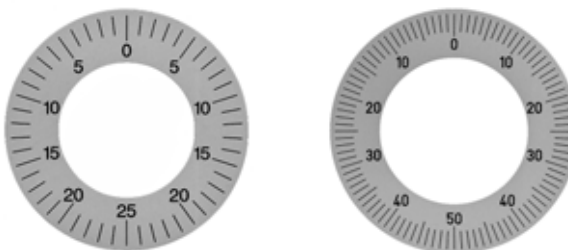

### Custom-made Dials

We can supply custom-made dials with special logos, with special numbers, with special imprints and in special colours. Both the inner and outer dials can be supplied in custom-made versions.

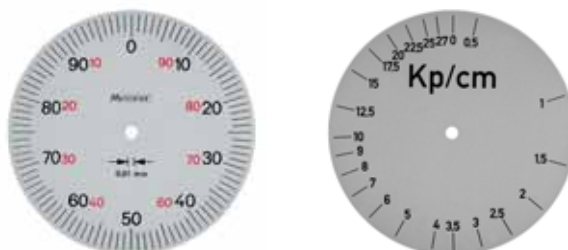

Special dials are available for many models but not for all Dial Gauges. Please request our offers.

## EXTRACTS OF MANUFACTURING STANDARDS FOR METRIC DIAL GAUGES

| Manufacturing standard | Field of application  | Span of error  | Range          | Maximum value   |
|------------------------|---|--|----------------|-----------------|
| 0.0500.9.0004          | Dial Gauges<br>with 0.1 mm reading  | Span of error $1/_{10}$ revolution<br>Span of error fe | 1 mm           | 30 $\mu$ m      |
|                        |   |  | up to 30 mm    | 50 $\mu$ m      |
|                        |   |  | 50 mm          | 80 $\mu$ m      |
|                        |   |  | 80 mm          | 100 $\mu$ m     |
|                        |   |  | 100 mm         | 100 $\mu$ m     |
| 0.0500.9.0006          | Dial Gauges<br>with 0.01 mm reading<br>and back plunger                             | Span of error $1/_{10}$ revolution<br>Span of error fe | 0.05 or 0.1 mm | 5 $\mu$ m       |
|                        |   |  | up to 3 mm     | 10 $\mu$ m      |
|                        |   |  | 5 mm           | 15 $\mu$ m      |
| 0.0500.9.0001          | High Precision Dial Gauges<br>with 0.001 mm reading<br>and 0.002 mm reading         | Span of error $1/_{10}$ revolution<br>Span of error fe | up to 3 mm     | 5 $\mu$ m       |
|                        |   |  | 5 mm           | 8 $\mu$ m       |
|                        |   |  | 5 mm           | 5 $\mu$ m       |
|                        |   |  | 10 $\mu$ m     | 3 $\mu$ m       |
|                        |   |  | 5 mm           | 0.5 $\mu$ m     |
| 0.0500.9.0010          | High Precision Dial Gauges FEINIKA<br>with 0.001 mm reading<br>and 0.002 mm reading | Span of error $1/_{10}$ revolution<br>Span of error fe | 0.02 mm        | 1.5 – 3 $\mu$ m |
|                        |   |  | 0.16 mm        | 3 $\mu$ m       |
|                        |   |  | 1 mm           | 5 $\mu$ m       |
|                        |   |  | 5 mm           | 10 $\mu$ m      |
|                        |   |  | 5 mm           | 3 $\mu$ m       |
| 0.0500.9.0010          | High Precision Dial Gauges FEINIKA<br>with 0.001 mm reading<br>and 0.002 mm reading | Span of error $1/_{10}$ revolution<br>Span of error fe | 0.01 mm        | 1 $\mu$ m       |
|                        |   |  | 0.08 mm        | 2 $\mu$ m       |
|                        |   |  | 0.16 mm        | 2 $\mu$ m       |
|                        |   |  | 1 mm           | 3 $\mu$ m       |
|                        |   |  | 1 mm           | 0.5 $\mu$ m     |
| 1.0200.9.0002          | Dial Gauges<br>with 0.01 mm reading<br>and range > 30 mm                            | Span of error $1/_{10}$ revolution<br>Span of error fe | 0.1 mm         | 5 $\mu$ m       |
|                        |   |  | 50 mm          | 25 $\mu$ m      |
|                        |   |  | 80 mm          | 30 $\mu$ m      |
|                        |   |  | 100 mm         | 50 $\mu$ m      |
|                        |   |  | 100 mm         | 3 $\mu$ m       |
| 1.0200.9.0014          | Dial Gauges<br>with 0.01 mm reading<br>and ranges 20 – 30 mm                        | Span of error $1/_{10}$ revolution<br>Span of error fe | up to 80 mm    | 3 $\mu$ m       |
|                        |   |  | 100 mm         | 5 $\mu$ m       |
|                        |   |  | 0.1 mm         | 5 $\mu$ m       |
|                        |   |  | 0.1 mm         | 20 $\mu$ m      |
|                        |   |  | 0.1 mm         | 3 $\mu$ m       |

Manufacturing standards for Dial Gauges MU 28 (4.0000.9.0012) and SI-18 (0.4223.9.0008) and for Inch Dial Gauges on request. Data sheets to DIN EN ISO 463: [www.kaefer-messuhren.de](http://www.kaefer-messuhren.de)